



**ADHESIVE - BONDED  
FASTENER TECHNOLOGY**

## CB787 Sleeve Trimmer Kit



Trims BOLTMOD® Sleeves to Create  
1<sup>st</sup> and 2<sup>nd</sup> Oversize 06 and 08 Bolts

- Eliminate the need for stocking oversize bolts
- Mitigates AOG status due to out-of-stock oversize bolts
- Less inventory, stock only 1" length 06 and 08 sleeves
- Kit includes all required tools\*
- Trimmer tool is precision-engineered for accuracy and durability
- Heavy-duty storage case makes tools easily accessible and portable

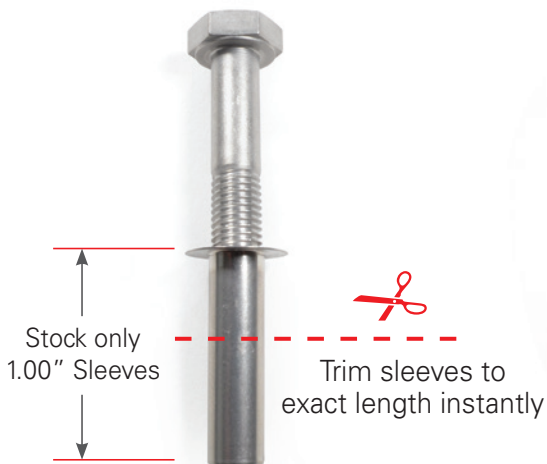

**PIONEERING > ADVANCED > SOLUTIONS**

\*Trimmer kit requires 200-500 RPM drill motor (not included)

## CB787 Sleeve Trimmer Kit | Kit Contents



**1 Case With Die Cut Foam and Label**

*Store tools when not in use, portable.*

**2 Deburr Tool**

*Used to smooth the end of the sleeve after trimming to remove any burrs left behind from the trimming operation.*

**3 Sleeve Trimmer Tool**

*Used with the piloted trimmers (13 and 14) to trim sleeves to the desired length.*

**4 1/8" Hex Wrench**

*Used to remove the set screw from the flat base if necessary.*

**5 1/16" Hex Wrench**

*Used to remove pilot pins from the trimmer when trimmer replacement is needed..*

**6 Sleeve Trimmer Base With 100 Degree Nose Center**

*Used to mate to the 100 degree sleeve during clamping to secure the sleeve during the trimming operation.*

**7 Sleeve Trimmer Base With Set Screw, Base**

*Used to fill the hole on the base to prevent shavings from filling the base during the trimming operation.*

**8 Size 06 Sleeve Trimmer First Oversize Clamp Plate\***

**9 Size 06 Sleeve Trimmer Second Oversize Clamp Plate\***

**10 Size 08 Sleeve Trimmer First Oversize Clamp Plate\***

**11 Size 08 Sleeve Trimmer Second Oversize Clamp Plate\***

**12 Sleeve Trimmer Cap**

*Used with the clamp plates to secure the sleeves in place during the trimming operation.*

**13 Size 06 Sleeve Trimmer With Pilot**

*This is the trimming bit used with the sleeve trimmer tool (3).*

**14 Size 08 Sleeve Trimmer With Pilot**

*This is the trimming bit used with the sleeve trimmer tool (3).*

**15 Flathead Screwdriver**

*Use to remove the 100 degree nose from the base if necessary.*

**16 Wrench**

*Both wrenches are used to tighten the cap against the base to secure the sleeve during the trimming operation.*

*\* NOTE: All clamp plates are used to securely hold sleeves against the base (either flush or 100 degree nose) during the trimming operation.*

**For use with Click Bond BOLTMOD® sleeve numbers JK5701, JK5721, JK5702, JK5722, JK5706, JK5726.**

©2020 Click Bond, Inc. All rights reserved. Click Bond and the stylized logo, and BOLTMOD®, are trademarks, or registered trademarks, of Click Bond, Inc. Registered, U.S. Patent and Trademark Office.

CB7200256-B

Printed in U.S.A.



2151 Lockheed Way  
Carson City, NV 89706  
+1.775.885.8000  
[WWW.CLICKBOND.COM](http://WWW.CLICKBOND.COM)